



BANDSLIJPMACHINE

QGRIND 100

De Qgrind 100 is een stabiele dubbele bandslijpmachine voor het ontbramen en voorslijpen van samples of andere materialen.

Het is mogelijk om gelijktijdig banden met 2 verschillende korrelgroottes te gebruiken. Het geproduceerde afvalmateriaal wordt afgevoerd door de watertoevoer.



KENMERKEN



EASY BELT EXCHANGE

Both shroud covers are made of stainless steel and are simply opened backwards. This allows free access to the individual belts. Rotate the front tension wheel to loosen the belt which can then be removed from the side. Similarly, by rotating the adjustment wheel, the new belt can be centred onto the middle of the working surface.



WATER-COOLING

A water film is created over the whole width of the front end of the belt. Waste material generated is carried to the back with the water and both are drained-off into the machine. Drain-offs are separated, one to the left, one to the right

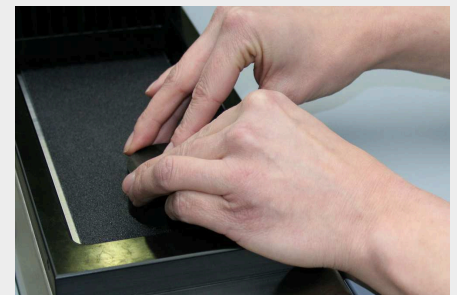

DRIVE

A powerful motor drives both belts at the same time. The rubber coated drive wheels, which are fitted with a special tread, prevent the belt from slipping.

PRODUCTVOORDELEN

- | Twee slijpbanden
- | Twee slijpbanden
- | Waterkoeling
- | water regulating valve left/right
- | aluminium design, powder coated
- | stainless steel cover

PERFECT GRINDING - CONSUMABLES BY QATM

Grinding is more reliable, safe and efficient when processed with the right ingredients: knowledge, care and the right choice of consumables and instruments.



TECHNISCHE GEGEVENS

QGRIND 100

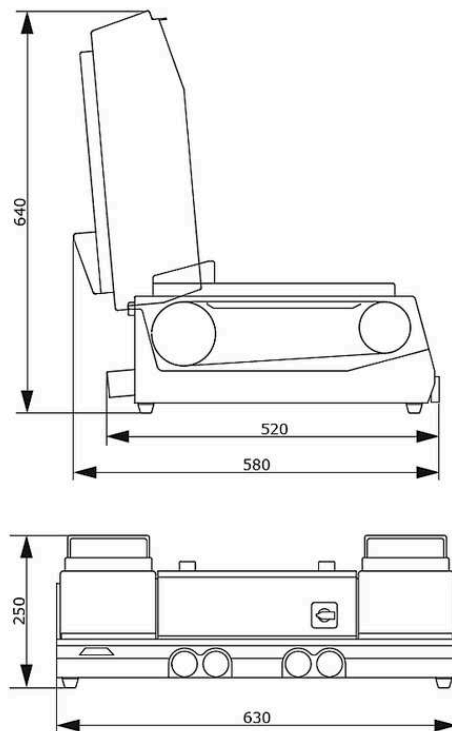

Grinding belts	endless grinding belts 100 x 920 / 100 x 915 mm
Belt speed	7 m/ sec
Water connectie	1x fresh water connection R½" max. 6 bars
Water uitlaat	right and left, ø 40 mm
Water valve	right and left
Aansluitvermogen	1.4 kVA
Vermogen aanrijving (hoofdaandrijving)	0.75 kW S6/60%
B x H x D	630 x 250 x 520 mm
Gewicht	~ 55 kg

www.qatm.com/qgrind-100

BESTELGEGEVENS

BASIS UITRUSTING

MACHINE (ALLE POSITIES NOODZAKELIJK)

M6000010 Qgrind 100 (Jade 700) Base machine



STROOMVOORZIENING (1 ITEM NOODZAKELIJK)

A6000001 Qgrind 100 power supply 400 50Hz (3Ph/N/PE)

A6000002 Qgrind 100 power supply 480 60Hz (3Ph/PE)

A6000003 Qgrind 100 power supply 220 60Hz (3Ph/PE)

OPTIES (KUNNEN AFZONDERLIJK BESTELD WORDEN)

Z5600008 Aansluitingsset

A5810261 Settling tank 45L for System Lab 2, mobile, with insertion mechanism for cabinet 800



A5810237 Bezinkingstank 45L voor System Lab 2, mobiel, met plaatsingsmechanisme voor kast 900



A5800496 Settling tank 45L for System Lab, mobile, without folding wheels

